

# Vertical dock leveller

The vertical leveller for loading docks is the **ideal solution for places that require strict temperature control and high levels of cleanliness**. Combined with other components such as inflatable shelters or sectional doors, it ensures a degree of protection of between 96 and 98%.

When not in use, the leveller is stored vertically, enabling the sectional door to be closed completely down to the ground, thus preventing possible leaks that could destabilise the inside temperature. In this way **efficiency is improved and energy loss is minimised**. This also leads to a reduction in the emission of **greenhouse gases** such as CO<sub>2</sub>, thereby contributing to a **more sustainable ecosystem**.

The truck's doors can be opened from inside the building, thus avoiding breaking the cold chain and aiding loading and unloading operations in the logistics centre.



## Technical description

- ✓ **The platform** is manufactured in 5/7 diamond plate and the fixed lip in 13/15 diamond plate.
- ✓ **Full rustproofing** and powder-sprayed with polymerised paint baked-on at 392 °F.
- ✓ **Hydraulic motor** unit with a 1.1 Kw (1.5 CV) – 400 V, three-phase engine, with a self-levelling system.
- ✓ **Lifting cylinder** with a **non-return valve** to avoid the dock falling abruptly.
- ✓ **Resistant** to temperatures from **-22°F to 122°F**.
- ✓ **Water-resistant electrical control** panel IP55 fitted with an emergency stop button.
- ✓ **Easy to operate**. The control panel allows simple and efficient operation in a sequential manner, saving on loading and unloading time.
- ✓ The Alapont vertical dock leveller **reduces energy loss in refrigerated vehicles**, making them an ideal solution for refrigerated trailers and installations that demand rigorous health standards such as the food and beverage or pharmaceutical sectors.
- ✓ When not in use, the leveller is stored vertically, there by enabling **the sectional door to be closed completely down to the ground**.



## Application

- 1 This is positioned vertically so that the door remains closed.
- 2 The HGV doors can remain closed and the driver does not need to leave the cabin.
- 3 The dock operator opens the vehicle doors from inside the building and lowers the dock leveller until it reaches the ideal position.
- 4 The loading and unloading process is undertaken as on a conventional dock.

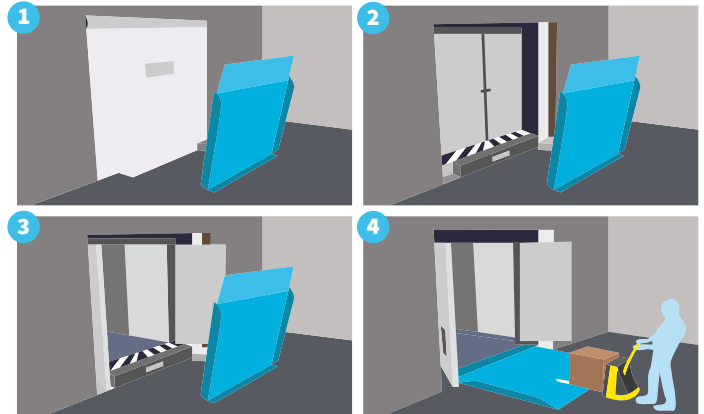

Static load capacity	9.000 kg
Dinamic load capacity	6.000 kg
Capacity	30000 lbs / 50000 lbs
Power supply	400V three-phase
Consumption	2A
Hydraulic group power	1,1 kw (1,5 CV)
Service pressure	170 bar
Flow	2,2cm 3/s
Colour	Standard: black RAL 9005. Possibility galvanized

## Safety specifications

- 1 The **non-return valve** on the cylinder prevents the platform from falling in the event of the rupture of a hose or failure of the hydraulic solenoid.
- 2 The **side baseboards** are high-visibility to comply with regulations.
- 3 **Sensor indicating position.**
- 4 Safety side socket.
- 5 **Safety pole** for maintenance tasks.
- 6 **Sensor** that enables the constant levelling of the dock on the HGV facilitating loading and avoiding harsh knocks during transport.
- 7 **STOP button** on the control station that stops the dock in its current position during an emergency.

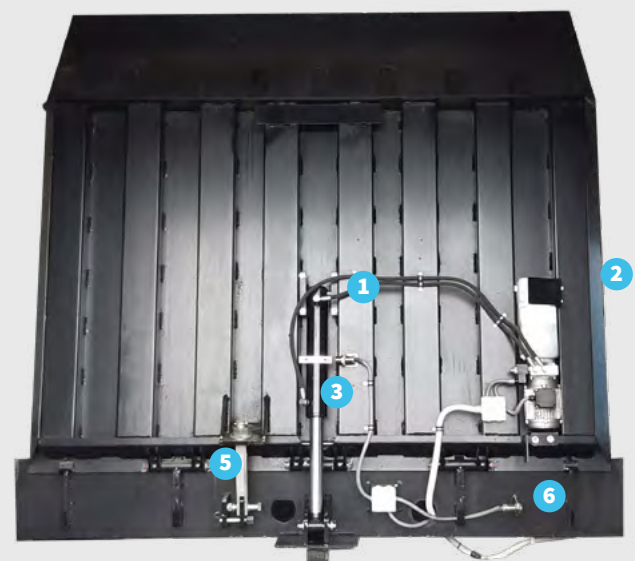

# Pit dimensions

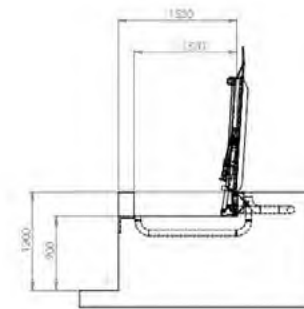
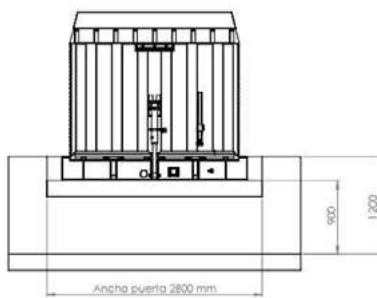
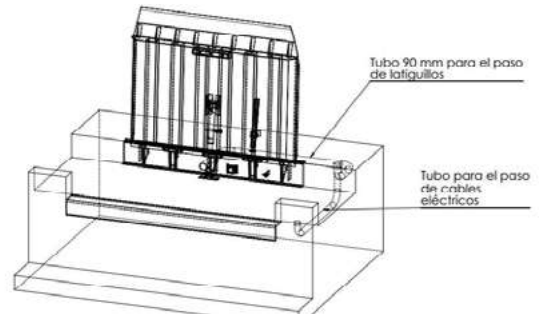
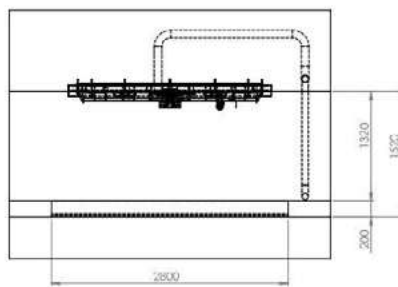

Leveller ( width x lenght )	Lip	Reference
87" x 73"	400	0106B0101000
87" x 94"	400	0106B0103000
6' x 8'	400	0206B0202000
6' x 8'	400	0206B0502000

